

How do I setup the Throttle Linkage?

The setup here is same for most heli carbs. The first thing needed is to check proper carb lever movement.

1. First off is to learn which way is Idle and which way is full throttle. Most carbs when you move the lever you can see the barrel slide in and outwards from the carb.. Looking at Fig 1, the blue portion is the barrel and when this portion moves inward (shortens) this is IDLE. When it moves outwards, this is FULL throttle.

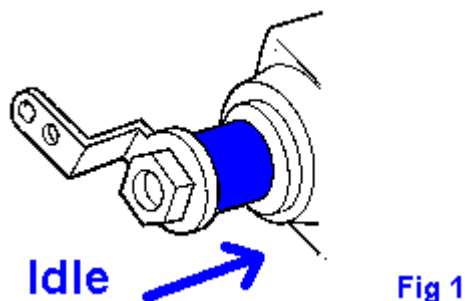

2. Now, looking at Fig 2, the carb lever is in the IDLE position. move the lever back and forth to its limits and make sure the arm DOES NOT go to, or past the imaginary blue line. If the lever can go to this point, its possible it can get stuck at FULL THROTTLE. If the lever is reaching this point it needs to be adjusted. Loosen the nut holding the lever on the carb slide. adjust the lever so that when the nut is tight, at full stop (idle) its ALMOST touches the frame.

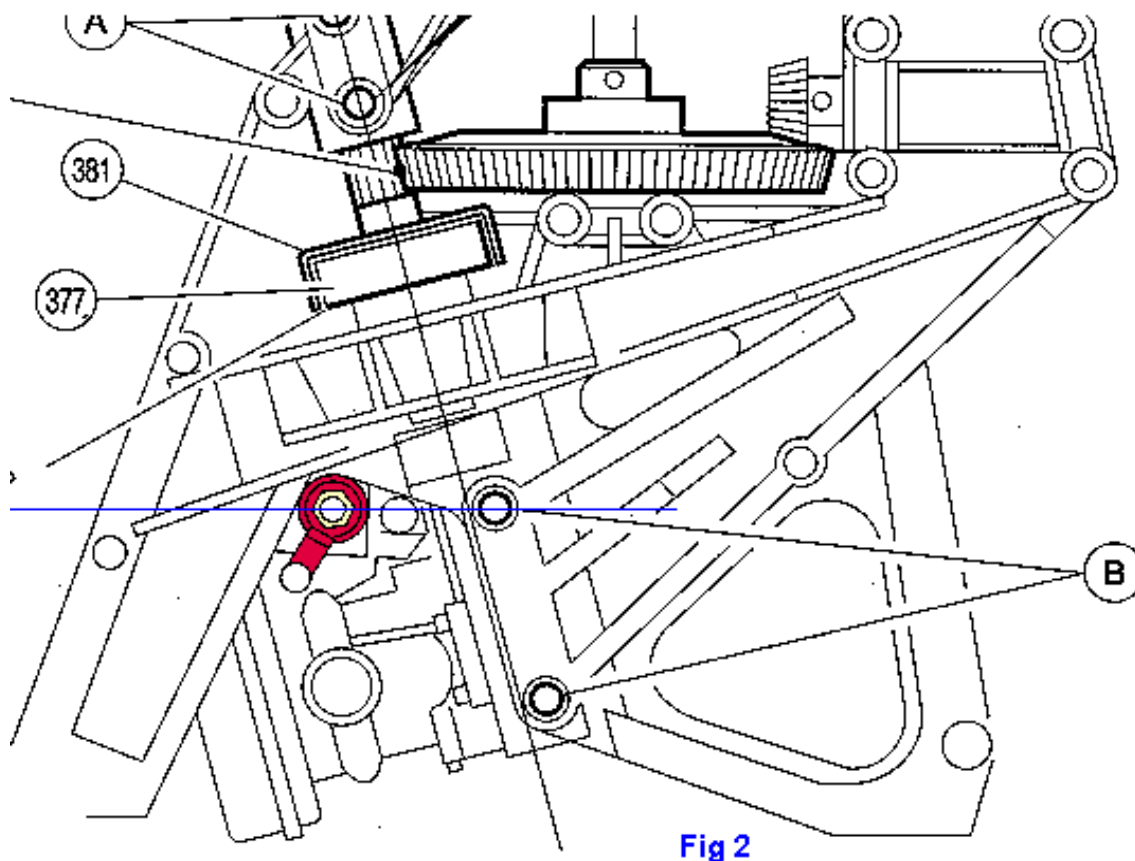

3. Now that the throttle lever is physically correct, we now need to adjust the radio so it knows where idle is, full throttle is, and throttle cut is..... Looking at Fig 3, place your link on the

carb lever ball, but DO NOT "snap" it on the ball. Just let it rest on it. Set the throttle sub trim to full down. Set the throttle stick to full down. Now look where the link is on the carb lever.. if its pulling past where the lever is stopped, then you need to lengthen the rod or adjust the low throttle atv's till the link comes back in line to where the ball is stopped (which should be almost touching the frame remember). If its not coming back far enough to where the lever is stopped, then you need to either shorten the rod or adjust the low atv's till it meets the ball...Move the throttle stick to full position now slowly... Watch the link to see if it is going past the point where the carb lever mechanically stops, or if its not fully going to the stop point (mechanical full throttle). Adjust either the rod length (this will now affect the already set low end) or the high end throttle atv's like you did the lows... So that now when you move the throttle stick it goes to full throttle and full closed WITHOUT binding... Now if you are at low stick, and move the throttle TRIM tab up you will see the lever slightly move too.... which is moving to idle. You may now "snap" the link onto the ball on the carb lever.

These tips are brought to you by Dave Townsend - Hobbytown USA heli dept.